

# DOUBLE BOLLARD

## ISO13795 - TYPE A

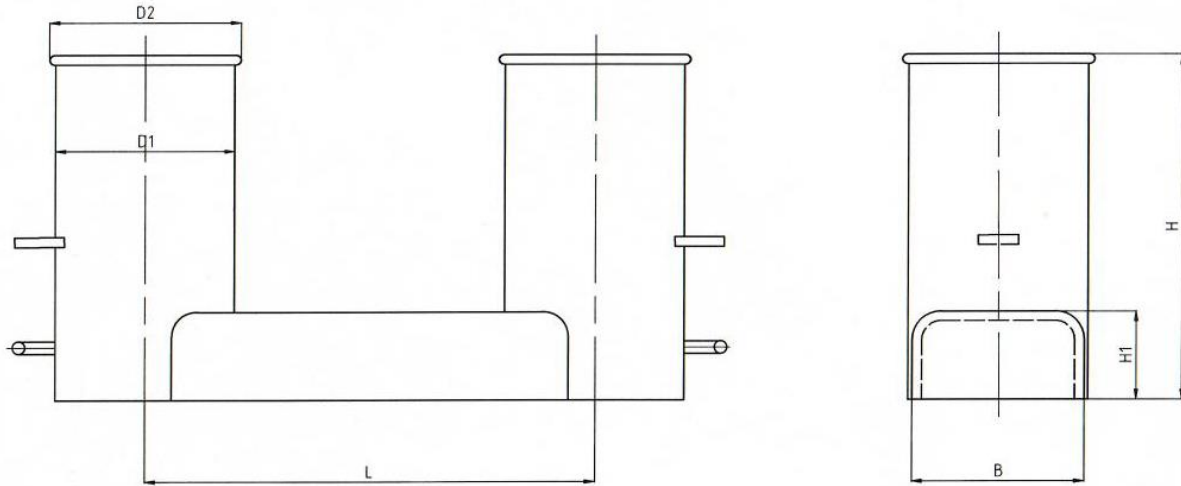

Material: Q235A

Finish: sand blasted and epoxy primer

Nominal Size Dn	D1	D2	H	H1	B	L	SWL (T) (one-rope use)	SWL (T) (two-rope use)	TOWING SWL (T)	Weight (kg)
150	165,2	185	330	90	155	400	5,5	5	10	29
200	216,3	240	395	115	205	500	8,4	6,7	13	46
250A	267,4	290	505	135	250	630	16	14	27	107
250B	267,4	290	505	135	250	630	13	11	22	91
300A	318,5	340	600	150	290	800	34	31	62	281
300B	318,5	340	600	150	290	800	19	16	36	166
350A	355,6	380	685	175	340	890	45	43	85	431
350B	355,6	380	685	175	340	890	25	22	50	241
400A	406,4	430	730	185	380	1000	61	53	106	570
400B	406,4	430	730	185	380	1000	33	27	67	322
450A	457,2	480	770	195	425	1100	77	62	124	712
450B	457,2	480	770	195	425	1100	39	30	78	379
500A	508,0	530	830	230	480	1250	101	77	154	960
500B	508,0	530	830	230	480	1250	47	33	93	465
550A	558,8	580	900	270	520	1380	115	83	165	1123
550B	558,8	580	900	270	520	1380	80	55	159	787
600	609,4	630	950	300	560	1550	143	97	193	1391

Dimensions in mm, alterations may occur.



Lemans Nederland B.V.  
 Canadaweg 8  
 4661 PZ Halsteren  
 The Netherlands

Tel.: +31(0) 164 680097  
 Fax: +31(0) 164 681971  
 E-mail: [info@lemans-nederland.eu](mailto:info@lemans-nederland.eu)  
 Website: [www.lemans-nederland.nl](http://www.lemans-nederland.nl)